

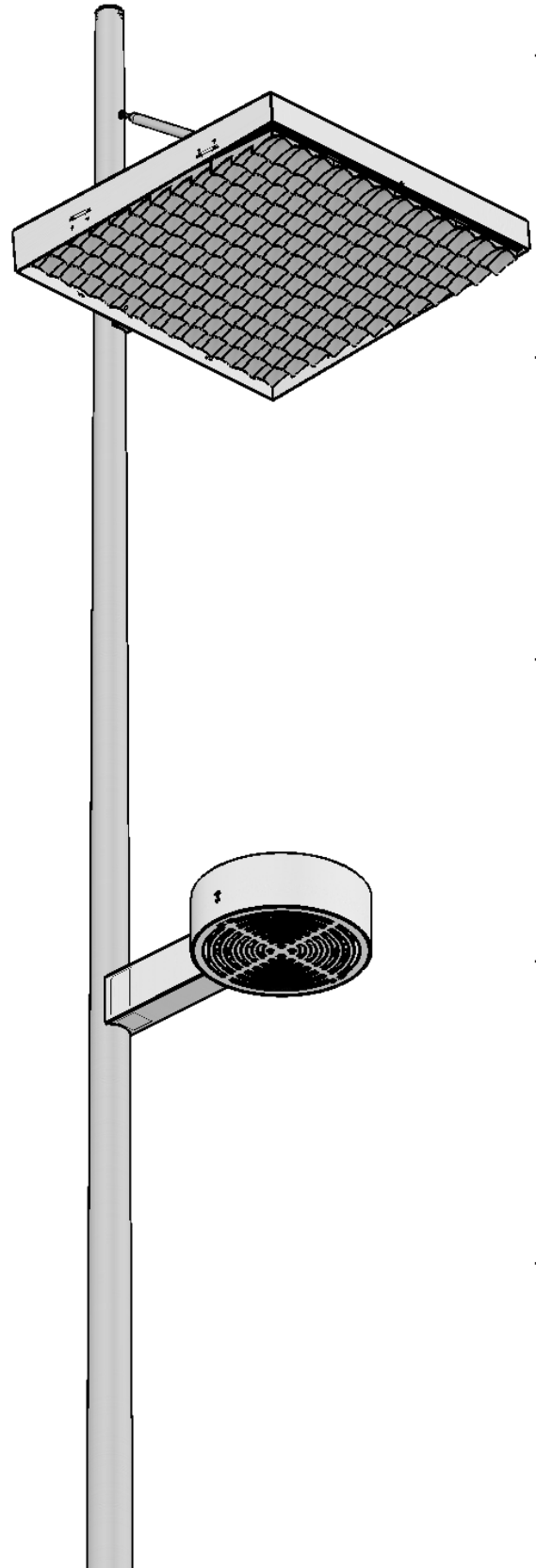

Gebrauchsanleitung
Installation and Operating Instructions
Notice de montage et d'installation
Manual de instrucciones
Istruzioni d'uso



V E D O P / S

ULTRA SPOT

(MIT GRIVEN STRAHLER JASPER)



2020/03/A

.hess



Wichtige Hinweise
Important Information
Consignes importantes
Observaciones importantes
Indicazioni importanti



(D) Montage- und Wartungsarbeiten sind nur mit Originalteilen durchzuführen. Für die Installation und den Betrieb sind die nationalen und internationalen Vorschriften zu beachten. Werden nachträglich Änderungen an Leuchten vorgenommen, so gilt derjenige als Hersteller, der diese Änderungen vornimmt. Hess Licht + Form übernimmt keine Haftung für Schäden, die durch unsachgemäßen Einsatz entstehen. Montage nur durch Fachpersonal.

(GB) Only use original parts for maintenance and installation of this luminaire. National and international regulations and laws apply to the installation and operation of this lighting fixture. If modifications are made to the luminaire, the party who made the modifications shall be considered the legal manufacturer thereafter. Hess Licht + Form does not accept liability for any damages that occur due to improper or unskilled actions. Only qualified persons are permitted to install and assemble products obtained from Hess Licht + Form.

(F) Tous travaux de montage et d'entretien ne doivent être effectués qu'avec des pièces d'origine. Observez les consignes de sécurité électriques nationales et internationales lors de l'installation et lors du fonctionnement. En cas de modifications ultérieurement apportées aux luminaires, la personne responsable de ces modifications est considérée comme le fabricant. Hess Licht + Form n'assume aucune responsabilité pour les dommages résultant d'une utilisation non conforme. Le montage ne doit être effectué que par des spécialistes.

(ES) Durante la instalación y el funcionamiento deben observarse las normativas nacionales e internacionales aplicables. En caso de modificaciones ulteriores en luminarias/postes, se considerará como fabricante quienquiera que haya efectuado dichas modificaciones. Hess Licht + Form declina cualquier responsabilidad sobre daños por uso indebido. Montaje únicamente por personal técnico cualificado.

(I) Per gli interventi di montaggio e di manutenzione vanno utilizzati esclusivamente pezzi originali. Per l'installazione e il funzionamento attenersi alle norme nazionali e internazionali. Se in un secondo tempo vengono apportate modifiche agli apparecchi, viene considerato costruttore chi ha effettuato le modifiche. Hess Licht + Form non risponde in alcun modo di danni causati da un impiego non corretto. Il montaggio va effettuato solo da personale esperto.

(D) Bei Wartungsarbeiten und beim Lampenwechsel muß das Element spannungsfrei sein. Es muß Schutzkleidung getragen werden.

(GB) When performing maintenance and changing the lamp, always make sure that the power is off in the luminaire (entire column). Protective clothing must be worn.

(F) Lors de tous travaux d'entretien et lors du remplacement d'une source lumineuse, il faut absolument mettre le module hors circuit. Il faut absolument porter un vêtement protecteur.

(ES) Durante los trabajos de mantenimiento y de sustitución de lámparas el módulo debe permanecer sin tensión, y se deberá llevar vestimenta de protección.

(I) Durante gli interventi di manutenzione e la sostituzione delle lampade il modulo non deve essere sottoposto a tensione. È inoltre necessario indossare abiti di protezione.

(D) Fremdmasten müssen gemäß DIN EN 40 zertifiziert sein.

(GB) All poles provided by others must be certified in compliance with DIN EN 40.

(F) Les mâts provenant de tiers doivent être certifiés selon DIN EN 40.

(ES) Los postes ajenos a Hess deben estar homologados según DIN EN 40.

(I) I pali di altri costruttori devono essere omologati secondo DIN EN 40.

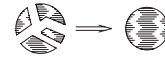

(D) Die Leuchte darf nur mit kompletter Schutzabdeckung betrieben werden.

(GB) Only operate this luminaire when it is in a closed state, i.e. with closed cover.

(F) Ne faire fonctionner le luminaire qu'avec le couvercle de protection fermé.

(ES) La luminaria debe funcionar únicamente con las cubiertas de protección al completo.

(I) L'apparecchio di illuminazione può essere utilizzato solo con le coperture di sicurezza complete.



(D) Es dürfen nur die vom Leuchtenhersteller vorgeschriebenen Ersatzteile eingesetzt werden. Die Vorschriften der Lampenhersteller sind zu beachten.

(GB) Only replacement parts specified by the lighting fixture manufacturer may be used. In addition, the lamp manufacturer's instructions must be followed.

(F) Seules les pièces de rechange prévues par le fabricant des luminaires doivent être utilisées. Observez les consignes du fabricant.

(ES) Se deben utilizar únicamente las lámparas y repuestos definidos por el fabricante. Deben observarse las indicaciones del fabricante.

(I) Possono essere utilizzati solo i ricambi prescritti dal costruttore dell'apparecchio. Attenersi alle norme del costruttore della lampada.

(D) Vorbereitende Arbeiten zum Aufstellen des Mastes entnehmen Sie bitte der separaten Empfehlung.

(GB) Please refer to the separate recommendation for preparatory work for erecting the pole.

(F) Concernant les travaux préliminaires pour l'installation du mât merci de consulter la recommandation ci-jointe.

(ES) Referente a los trabajos preparatorios para la instalación del poste consulte por favor la recomendación adjunta.

(I) Per i lavori preparatori per l'installazione del palo, fare riferimento alla raccomandazione separata.

(D)



(GB)



(F)



(D) LED-Modul: Risikogruppe 2, nicht in den Strahl blicken!
Die Leuchte ist so zu positionieren, dass längeres in die Leuchte schauen in einem geringeren Abstand als 0,4m nicht zu erwarten ist.

(GB) LED module risk group 2, do not look into the beam!
Position the luminaire to avoid extended viewing into the luminaire at a distance of less than 0,4m.

(F) Module LED, groupe des risques 2, ne pas regarder le rayon.
Positionnez le luminaire afin d'éviter d'y regarder longtemps à une distance inférieure à 0,4m.

(ES) Módulo LED grupo de riesgo 2, no fije la vista en le rayo.
La luminaria debe posicionarse de tal manera que se evita mirar directamente a la luz a una distancia menor a 0,4m durante un tiempo prolongado.

(I) Modulo LED gruppo a rischio 2, non fissare direttamente la luce.
L'apparecchio deve essere posizionato in modo da evitare la possibilità di volgere a lungo lo sguardo verso di esso ad una distanza inferiore a 0,4m.



(D) PMMA Reinigung
Leuchtenabdeckungen aus PMMA-Kunststoff dürfen nur mit Wasser und Spülmittel, bei starken Verschmutzungen mit Waschbenzin gereinigt werden. Andere Mittel sind nicht erlaubt, insbesondere die Verwendung von alkoholhaltigen Reinigern (Spiritus, Glasreiniger, etc.) oder Kaltreinigern führen zur Beschädigung der Oberfläche.

(GB) PMMA cleaning instructions
Only use a mild detergent and water to clean luminaire covers and enclosures of PMMA plastic. If the PMMA is very heavily soiled, you may use benzene, but with great care and sparingly. Do not use any other agents; in particular, alcohol-containing cleaners (spirits, glass cleaner, etc.) or cold cleaning solvents will damage the surface of the PMMA.

(F) Conseil de nettoyage
Les couvercles de luminaire en matière plastique (de verre acrylique) sont à nettoyer exclusivement avec de l'eau et un produit vaisselle, l'éther de pétrole est autorisé en cas d'encrassements tenaces. Tout autre produit est proscrit, notamment l'emploi de détergents contenant de l'alcool (white-spirit, produits pour vitres, etc.) ou de détergents à froid qui endommageraient la surface.

(ES) Indicaciones para la limpieza
Las cubiertas de luminaria en metacrilato deben limpiarse únicamente con agua y detergente, y con éter de petróleo en caso de suciedad importante. Se prohíbe utilizar otros agentes de limpieza. Los agentes de limpieza que contengan alcohol (alcohol etílico, limpiacristales, etc.) o desengrasantes, en particular, pueden dañar la superficie.

(I) Indicazioni per la pulizia
Per la pulizia degli schermi in polimetilmetacrilato utilizzare solo acqua e detergente o benzina solvente in caso di forte imbrattamento. Non è consentito l'impiego di altri mezzi; in particolare detersivi contenenti alcol (spirito, detergente per vetri, ecc.) o detersivi a freddo danneggiano la superficie.



Lieferumfang
 Included in Luminaire Purchase
 Matériel fourni
 Programa de entrega
 Volume di consegna

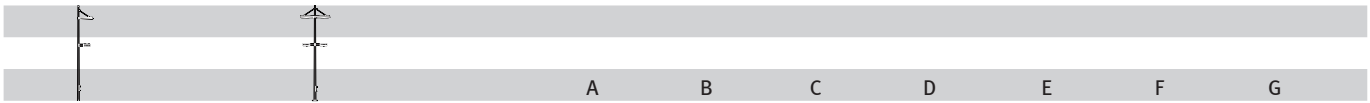

VEDO P

		A	B	C	D	E	F	G
		mm	mm	mm	Ømm	mm	Ømm	mm
10.00600.6500	10.00602.6500	6500	1200	7500	163	1010	400	300
10.00600.8000	10.00602.8000	8000	1500	9000	181	1010	400	300
10.00600.10000	10.00602.10000	10000	1500	12000	224	1010	400	300
10.00600.12000	10.00602.12000	12000	1500	13300	237	1250	400	300

VEDO S

10.00610.6500	10.00612.6500	6500	1200	7500	163	1010	400	300
10.00610.8000	10.00612.8000	8000	1500	9000	181	1010	400	300
10.00610.10000	10.00612.10000	10000	1500	12000	224	1010	400	300

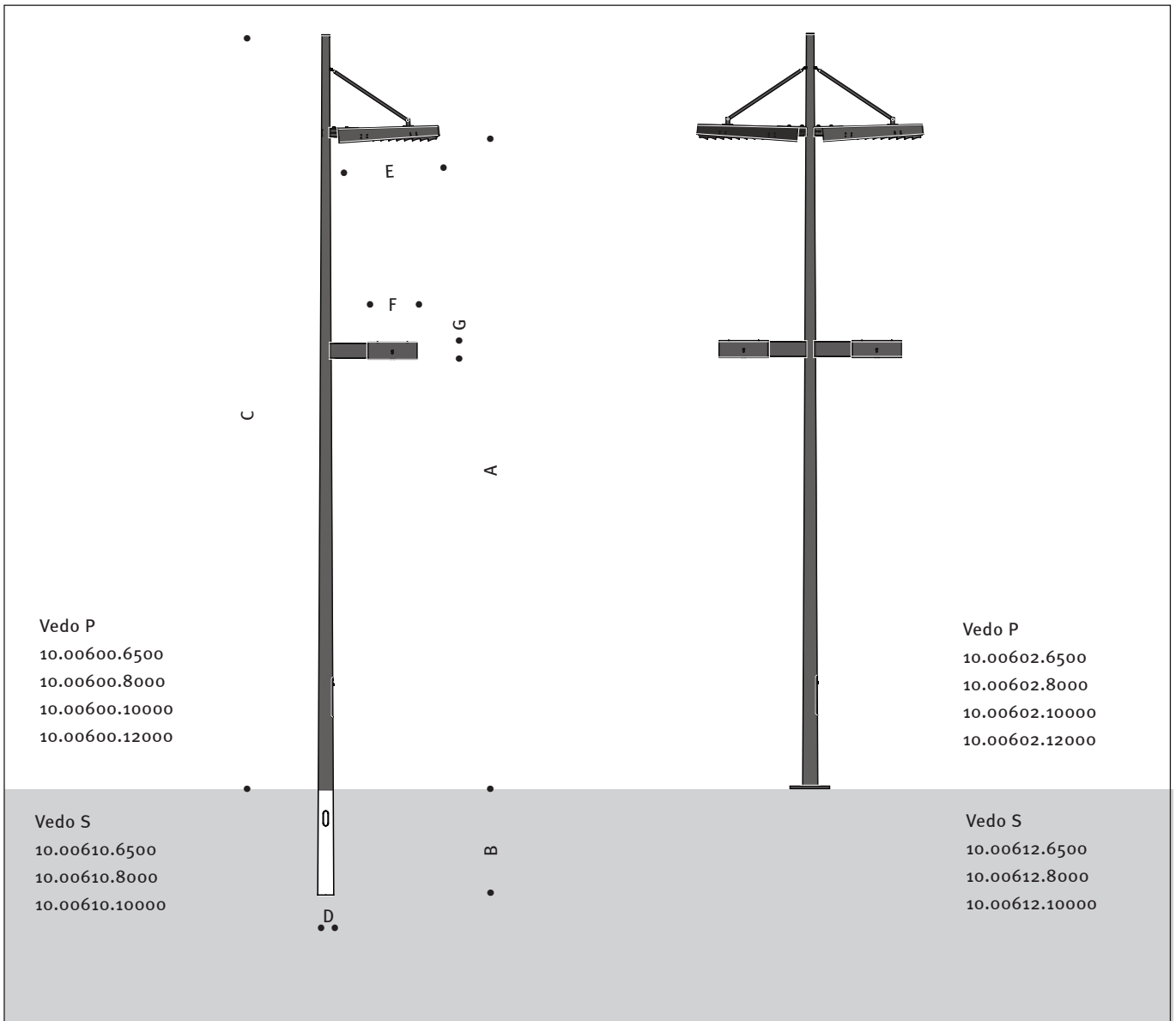



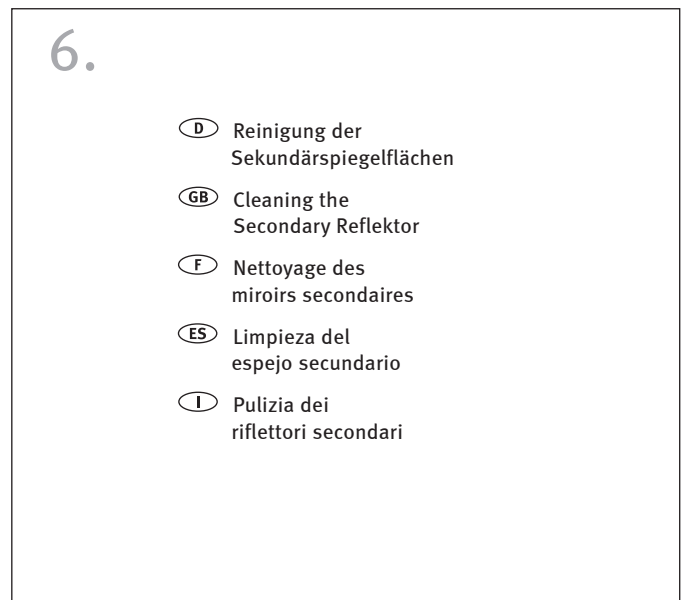
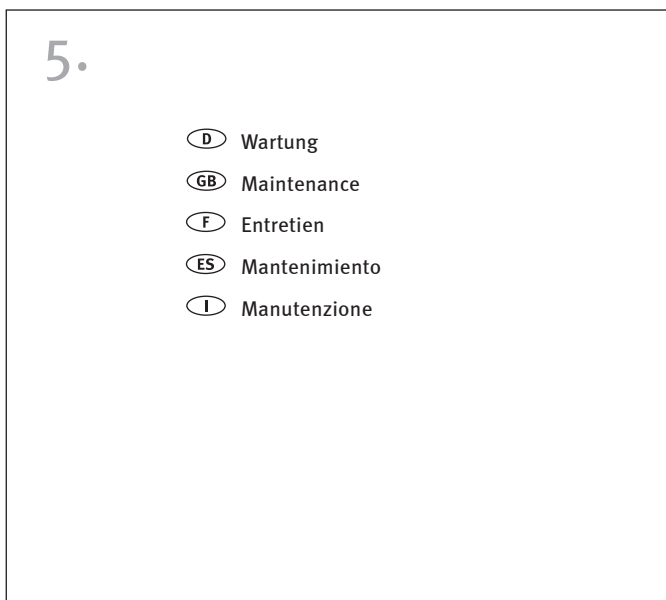
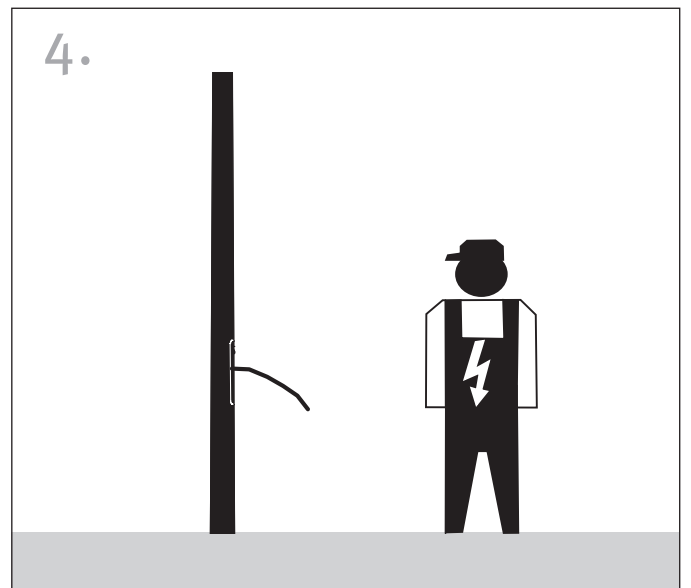
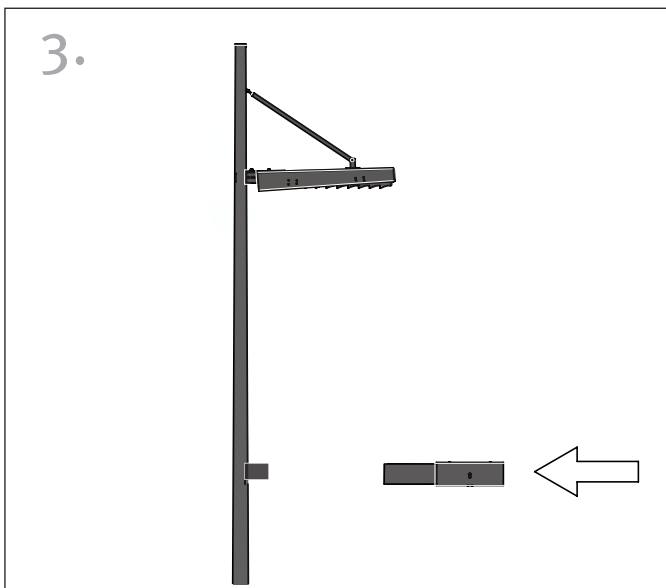
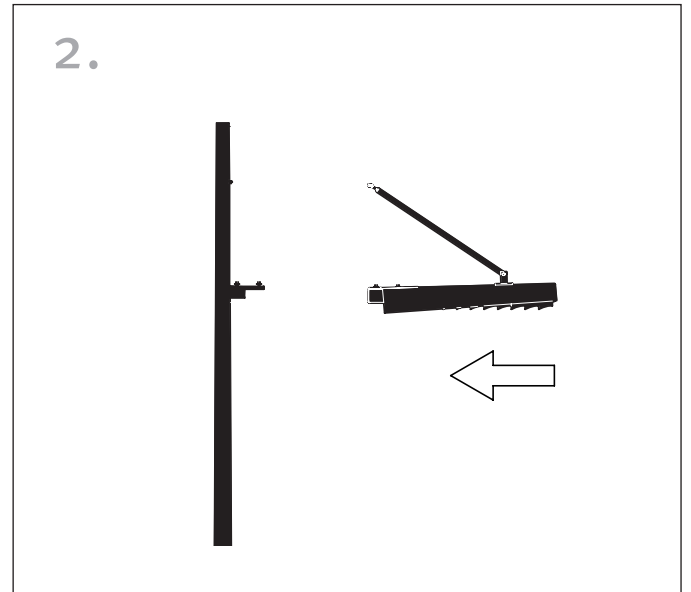
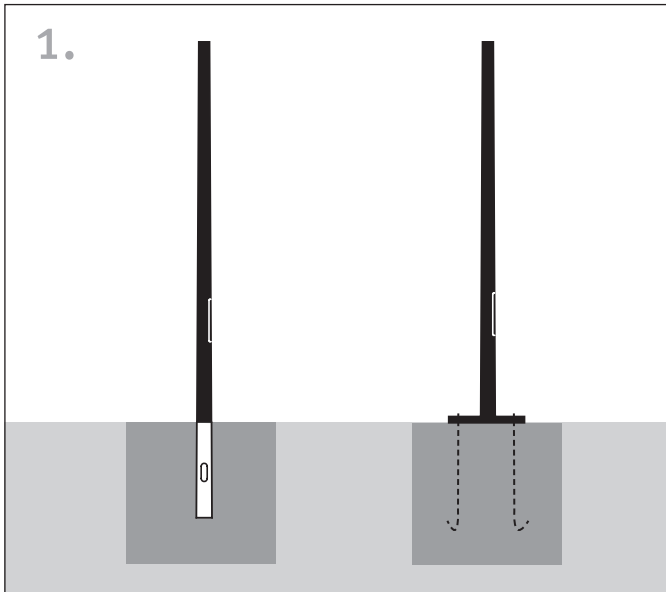

Empfohlene Montagefolge
Recommended Installation Procedure
Déroulement de montage recommandé
Secuencia de montaje recomendada
Sequenza di montaggio consigliata





Gewichte / Windangriffsflächen
 Weight / Wind Catching Surface
 Poids / Surface de résistance au vent
 Pesos / Superficie expuesta al viento
 Pesì / Superficie di resistenza al vento

VEDO P	VEDO S	A	B	 kg	 m ³	
10.00600.6500	10.00610. 6500	6500	1200	127	2,8	Q 400x25
10.00600.8000	10.00610. 8000	8000	1500	165	3	Q 400x25
10.00600.10000	10.00610.10000	10000	1500	255	3,7	Q 400x30
10.00600.12000		12000	1500	284	4	Q 500x40
10.00602.6500	10.00612. 6500	6500	1200	177	4,7	Q 400x25
10.00602.8000	10.00612. 8000	8000	1500	215	4,9	Q 400x30
10.00602.10000	10.00612.10000	10000	1500	305	5,6	Q 400x35
10.00602.12000		12000	1500	334	5,9	Q 500x40

1.

Mast aufstellen
 Putting Up the Pole
 Ériger le mât
 Montaje del poste
 Montaggio del palo

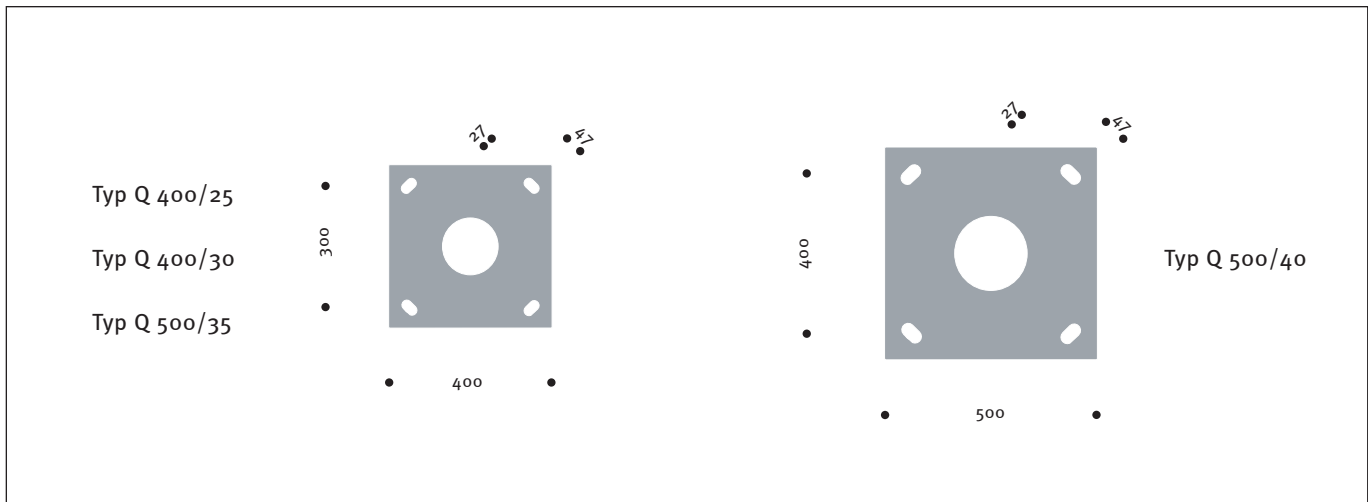
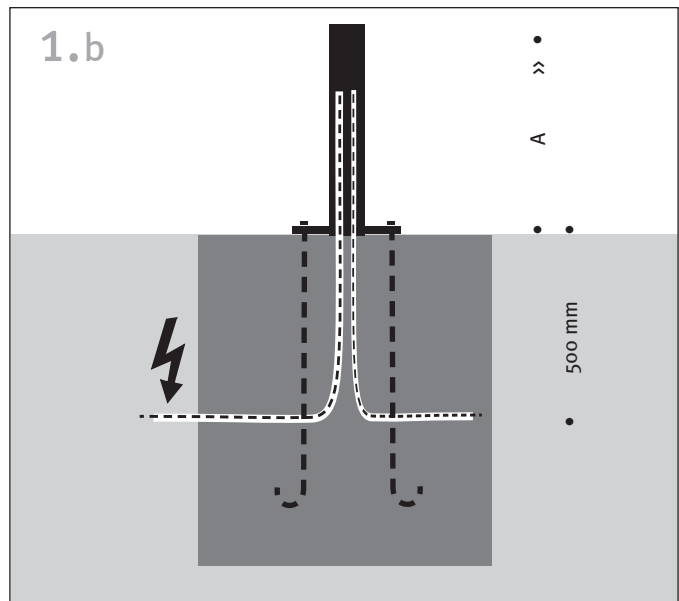
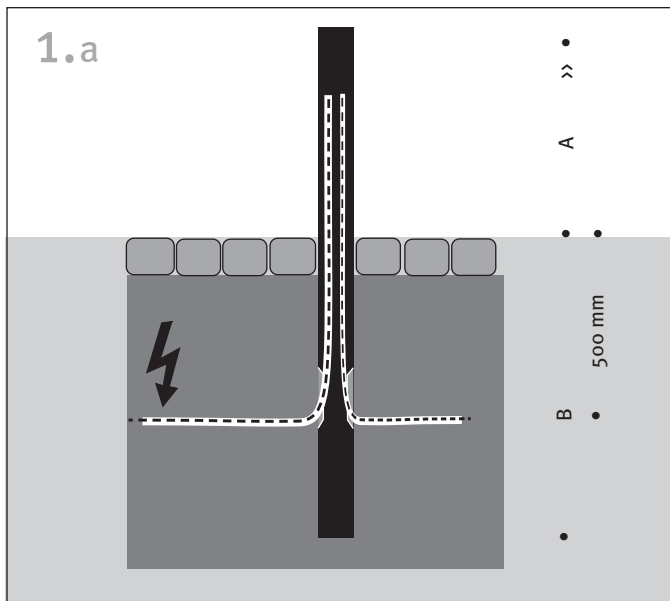

2.

Montage
Mounting
Montage
Montaje
Montaggio

2.1

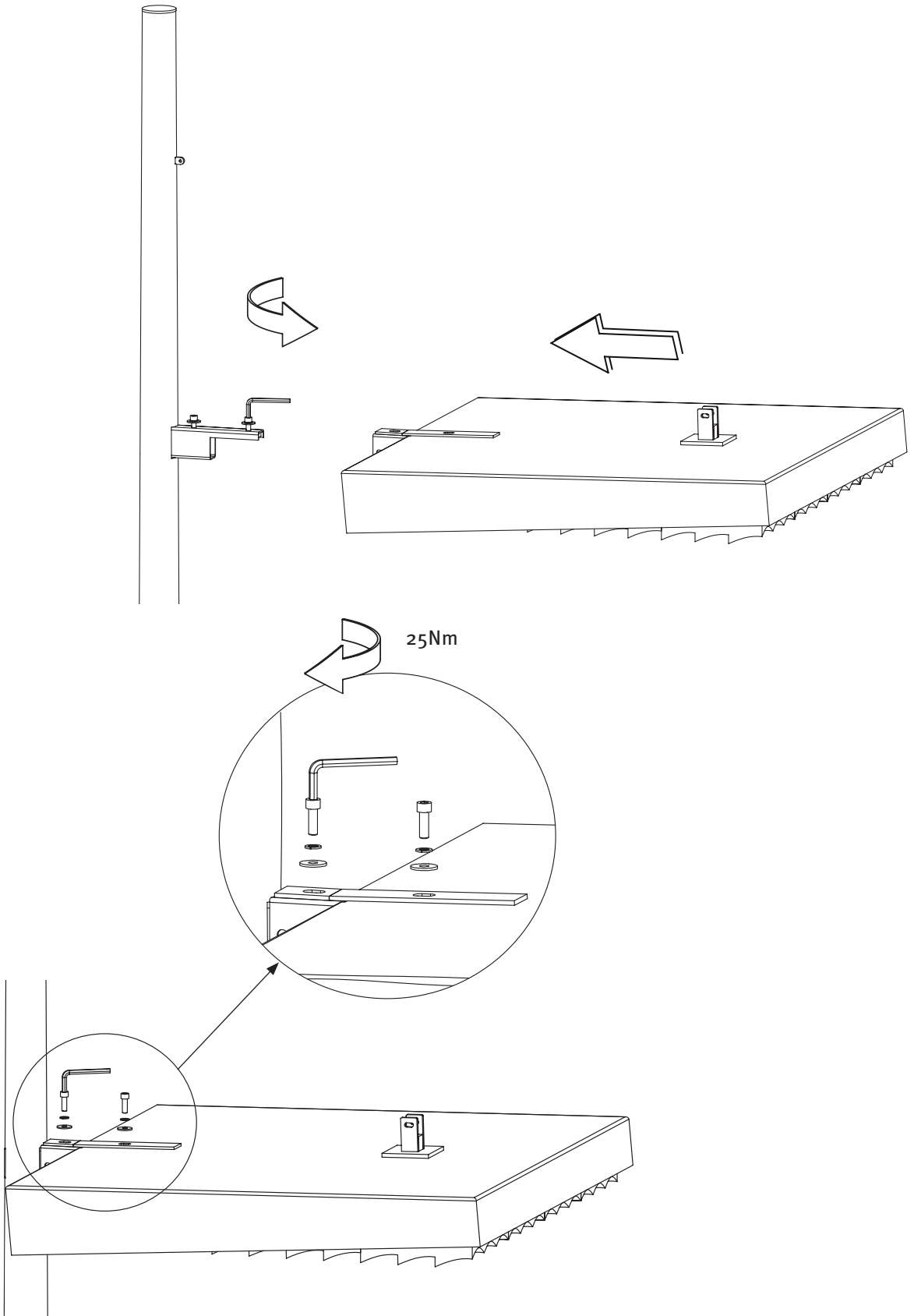

2.

Montage
Mounting
Montage
Montaje
Montaggio

2.2

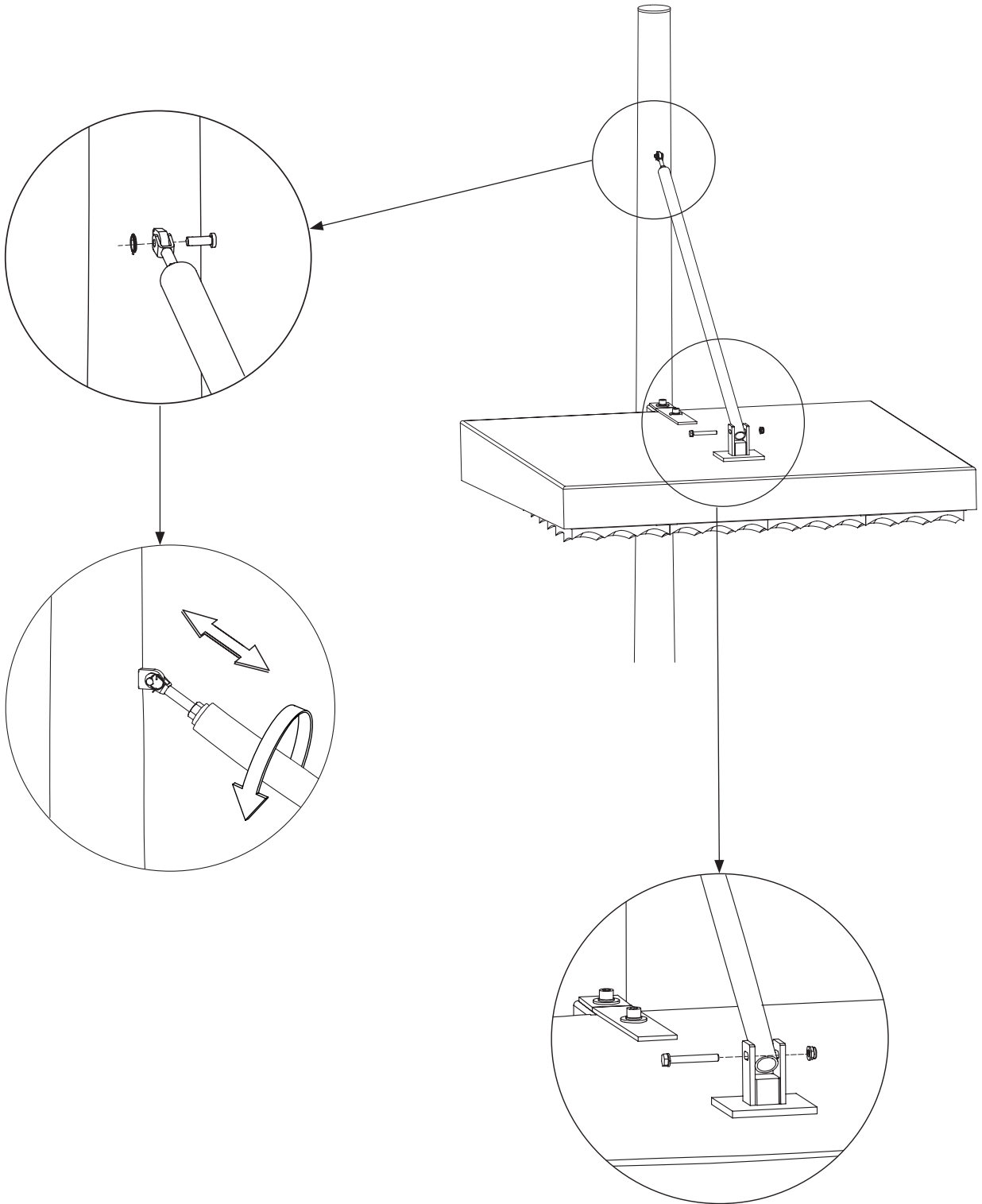

3.

Montage
Mounting
Montage
Montaje
Montaggio

3.1

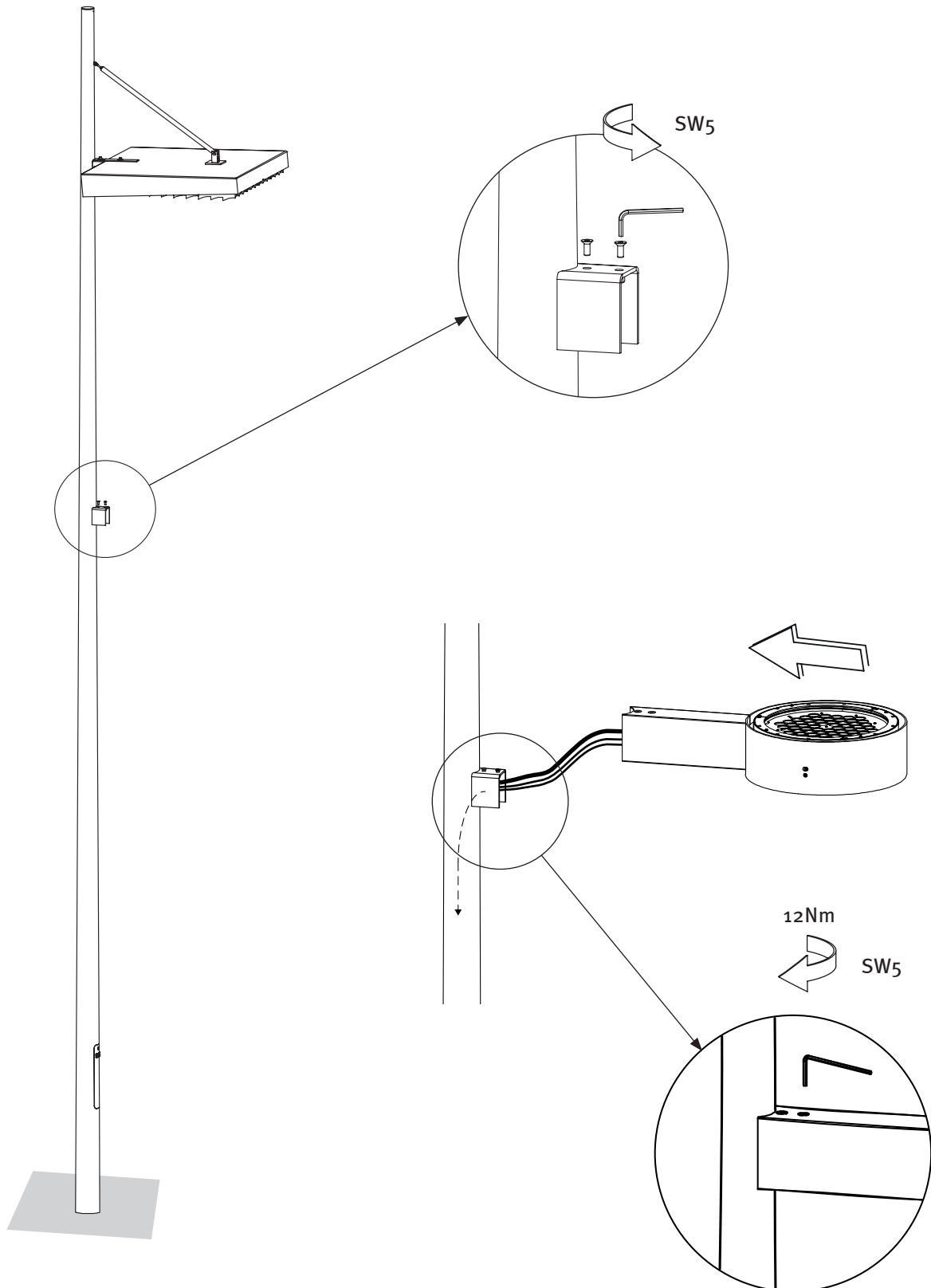

3.

Montage
Mounting
Montage
Montaje
Montaggio

3.2

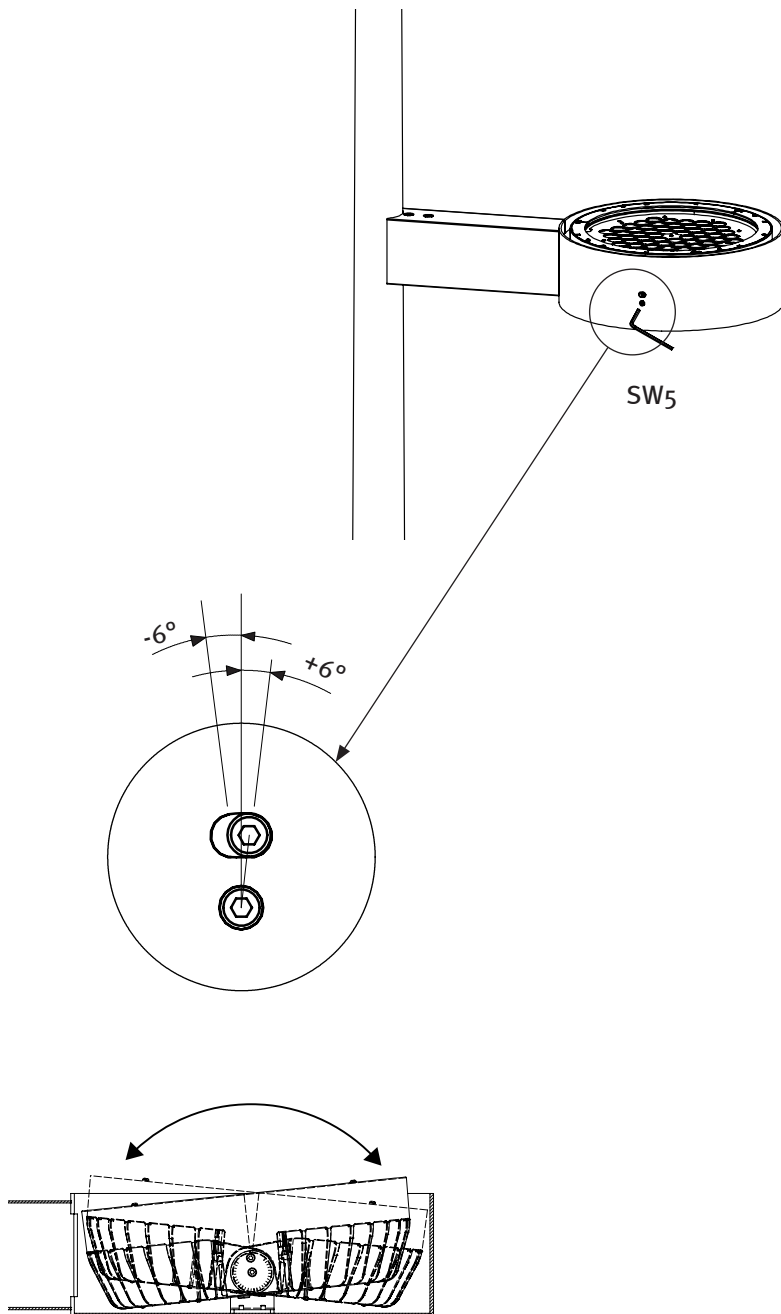

- Ⓓ Strahler einstellen
- ⒼⒷ Adjust the spotlight
- Ⓕ Ajuster le projecteur
- Ⓔ Ajusta el foco
- Ⓘ Regola il riflettore

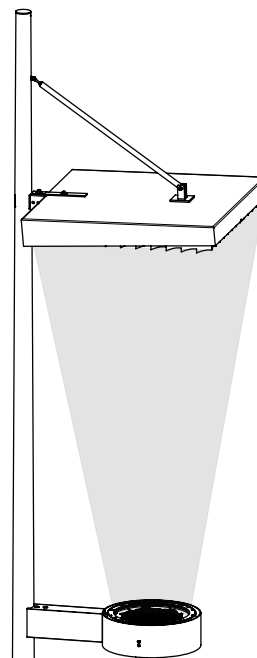

4.

Kabelübergangskasten
 Junction Box
 Boîtier de raccordement
 Caja de empalmes
 Cassetta di distribuzione per i cavi

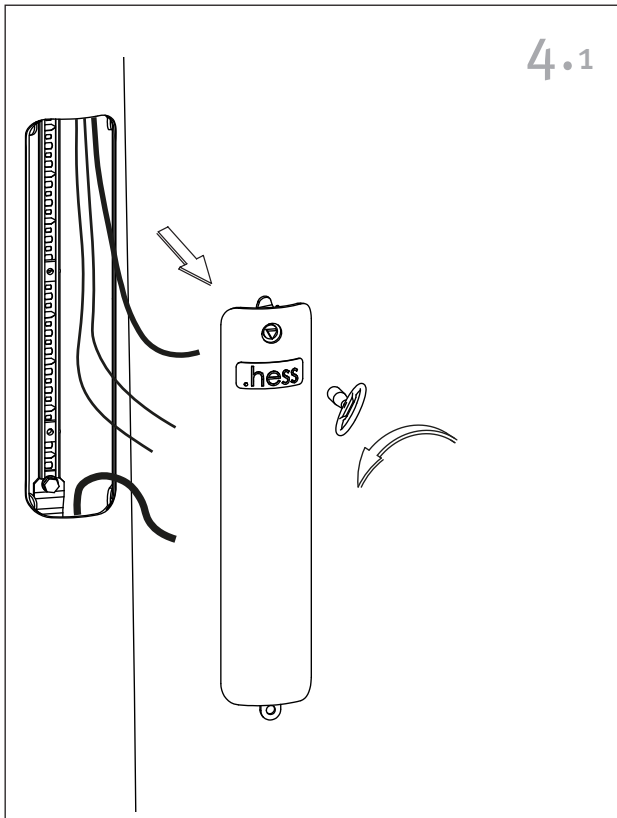

4.1

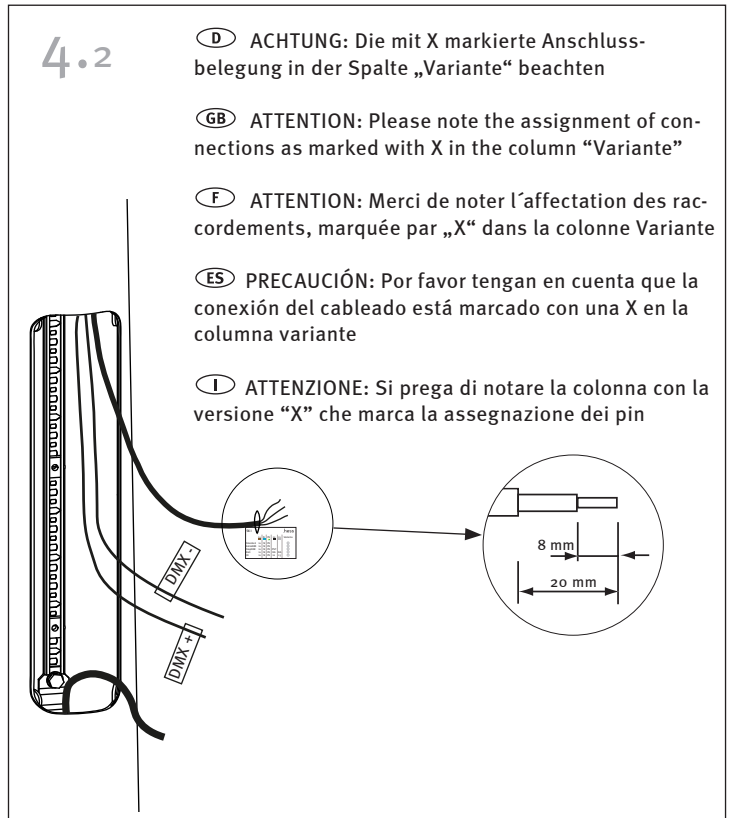

4.2

- (D)** ACHTUNG: Die mit X markierte Anschlussbelegung in der Spalte „Variante“ beachten
- (GB)** ATTENTION: Please note the assignment of connections as marked with X in the column “Variante”
- (F)** ATTENTION: Merci de noter l’affectation des raccordements, marquée par „X“ dans la colonne Variante
- (ES)** PRECAUCIÓN: Por favor tengan en cuenta que la conexión del cableado está marcado con una X en la columna variante
- (I)** ATTENZIONE: Si prega di notare la colonna con la versione “X” che marca la assegnazione dei pin

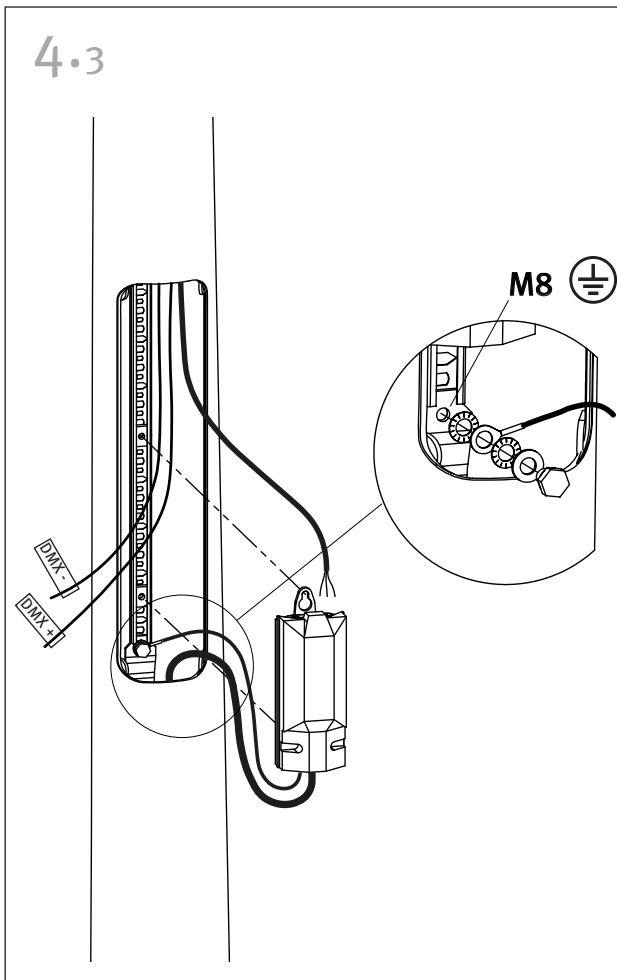

4.3

- (D)** Der Kabelübergangskasten ist nicht im Lieferumfang enthalten, er muss VDE, ENEC und für die Montage auf C-Schienen zugelassen sein, sowie der Schutzklasse und Schutzart der Leuchte entsprechen. Die Schraubenanschlussklemmen müssen für das Auflegen der verwendeten Kabel zugelassen sein.
 Empfehlung: TYCO EKM 2051
- (GB)** The junction box does not come with the purchase of the luminaire. It must be VDE- and ENEC-approved. In addition, it must be approved for mounting to C-profile tracks and must be suitable for use with the respective luminaire’s Protection Rating and Ingress Protection classifications. The screw terminals must also be suitable for the respective wiring that is used.
 Recommendation: TYCO EKM 2051
- (F)** Le boîtier de raccordement n’est pas inclus dans la livraison. Il doit être homologué VDE/ENEC ainsi que pour son montage sur des rails de transport et il doit correspondre à la classe électrique et à l’indice de protection du luminaire. Les bornes à vis doivent permettre d’appliquer des câbles utilisés.
 Recommendation: TYCO EKM 2051
- (ES)** La caja de empalmes, que no está incluida en el programa de entrega, debe cumplir con VDE/ENEC y estar homologada para montaje en rieles en C, así como corresponder a la clase y tipo de protección de la luminaria. Los bornes de conexión atornillados deben permitir el tendido del cable que se utilice.
 Recomendación: TYCO EKM 2051
- (I)** La cassetta di distribuzione per i cavi non è in dotazione, deve essere omologata secondo VDE/ENEC e per il montaggio su guide a C e inoltre corrispondere alla classe di isolamento e al grado di protezione dell’apparecchio. I morsetti a vite devono consentire il collegamento dei cavi utilizzati.
 Raccomandazione: TYCO EKM 2051

5.

Wartung
Maintenance
Entretien
Mantenimiento
Manutenzione

5.1

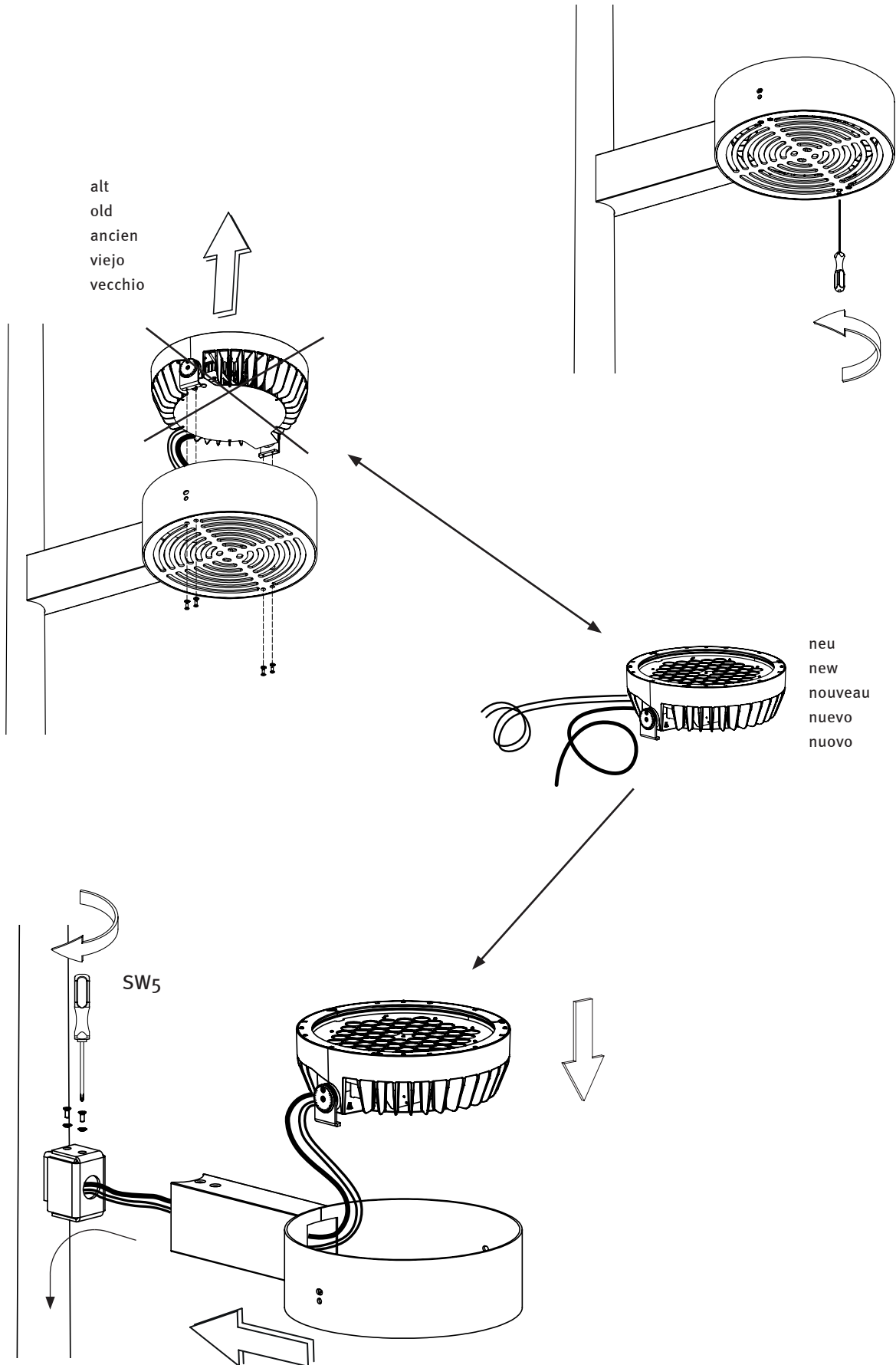

5.2

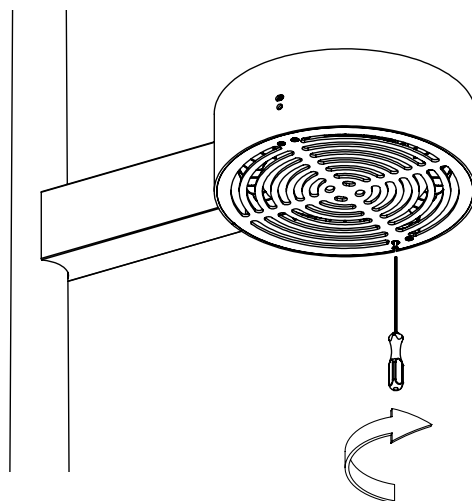

- Ⓓ Strahler einstellen
- ⒼⒷ Adjust the spotlight
- Ⓕ Ajuster le projecteur
- Ⓔ Ajusta el foco
- Ⓘ Regola il riflettore

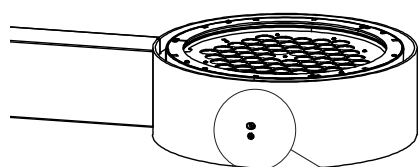

SW5

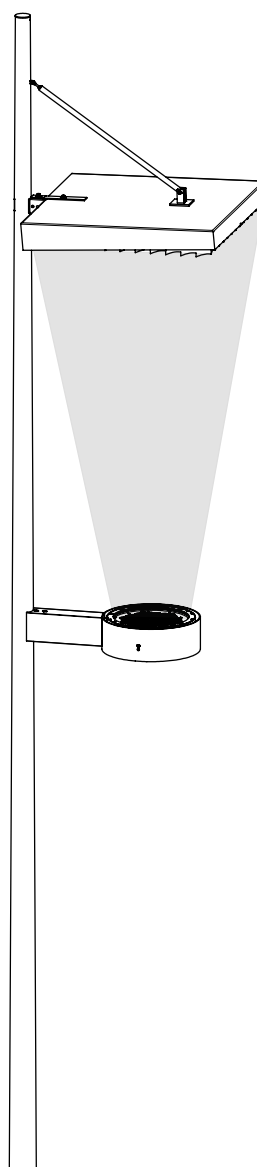
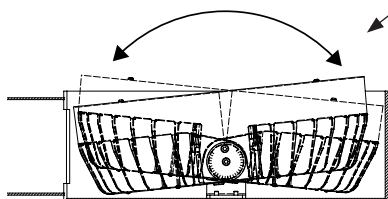
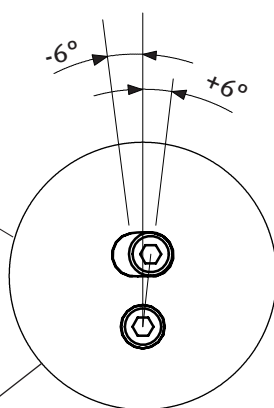

6.

Reinigung der Sekundärspiegelflächen
Cleaning the Secondary Reflector
Nettoyage des miroirs secondaires
Limpieza del espejo secundario
Pulizia dei riflettori secondari

6.1



(D) VORSICHT: Zerstörungsgefahr. Keine Hochdruck-Reinigungsgeräte verwenden. Zugelassenes Reinigungsmittel: Multi-Star-Gescha (www.multi-star-ammerland.de)

(GB) CAUTION! To avoid damage, do not use high pressure cleaning systems (air or water). Approved cleaning agent: Multi-Star-Gescha, available from www.multi-star-ammerland.de

(F) ATTENTION : Risque de destruction. Ne pas utiliser des dispositifs de nettoyage à haute pression. Détergent agréé : Multi-Star-Gescha (www.multi-star-ammerland.de)

(ES) PRECAUCIÓN: Peligro de destrucción. No utilizar aparatos de limpieza a alta presión. Agentes de limpieza permitidos: Multi-Star-Gescha (www.multi-star-ammerland.de)

(I) ATTENZIONE! Rischio di distruzione. Non utilizzare apparecchi di pulizia ad alta pressione. Detergente consentito: Multi-Star-Gescha (www.multi-star-ammerland.de)

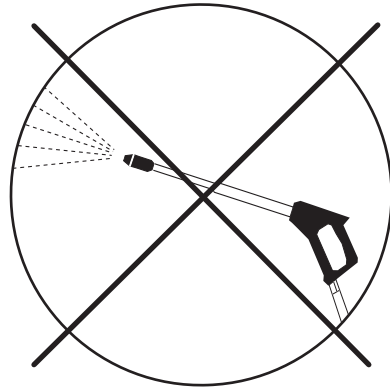

6.2

1 : 10

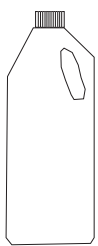

Multi
Star
Gescha



H₂O
W 50°C

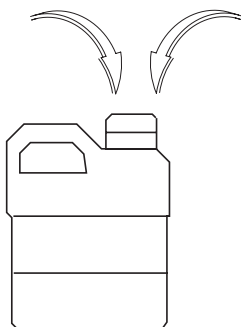

6.3

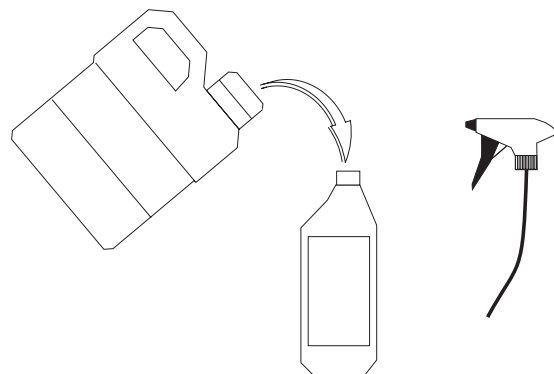

6.4

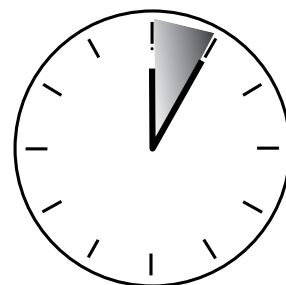
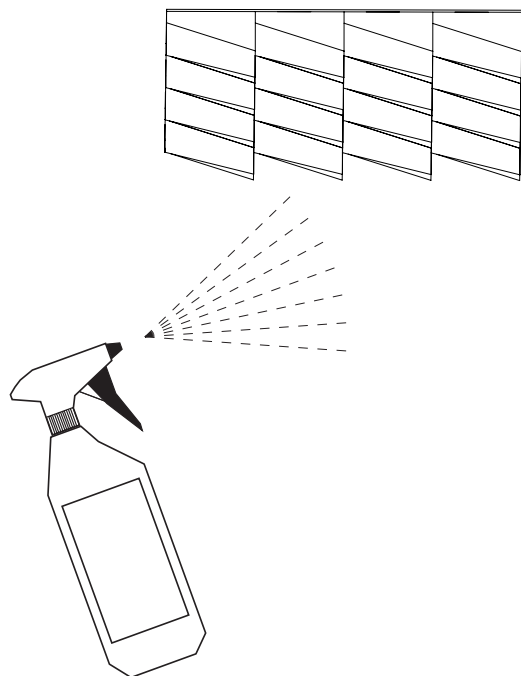

5 Min.

6.5

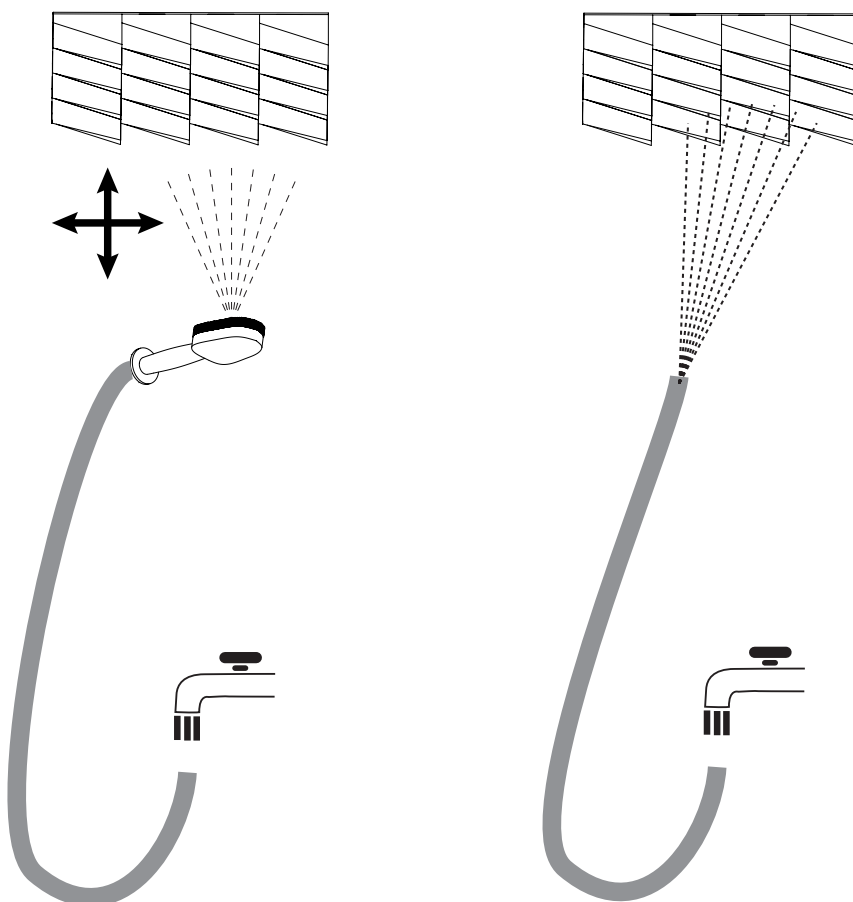

(D) ACHTUNG: Bürste mit weichen Borsten verwenden.

(GB) CAUTION! To avoid damage, only use brushes with soft bristles.

(F) ATTENTION ! Risque de destruction: Utiliser une brosse à soies douces

(ES) ¡ATENCIÓN! Peligro de destrucción: utilizar un cepillo con cerdas blandas

(I) ATTENZIONE! Rischio di distruzione: utilizzare una spazzola dalle setole morbide

Hess Gmbh
Licht + Form
Lantwattenstraße 22
D-78050 Villingen-Schwenningen
Tel. +49 7721 / 920-0
Fax +49 7721 / 920-250
info@hess.eu
www.hess.eu